

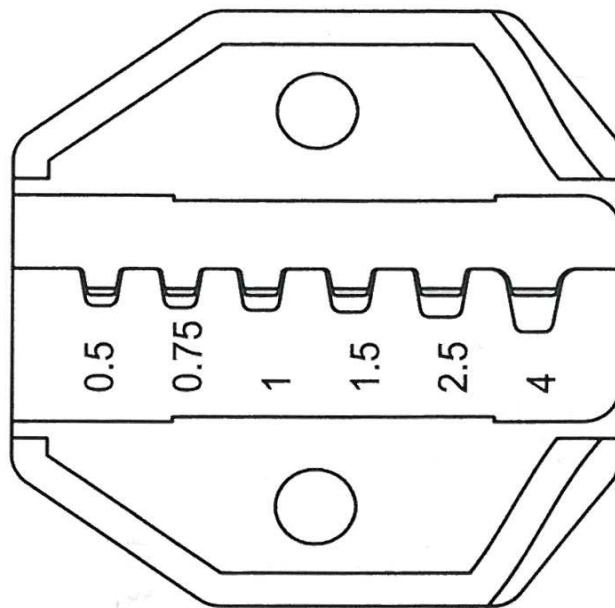

Presseinsatz für MP 1 und MP 2
für Aderendhülsen

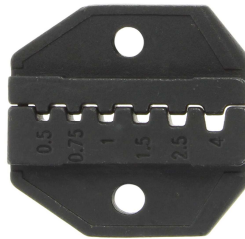

| | | | | |
|---------------------|---------------------------------------|--|-------------------------------------|--|
| Art. Nr. | Pressform | | |  |
| W 9060809 | trapez | | | 1 |
| Crimpstation | 1 | 2 | 3 | |
| Querschnitt | 0,5 mm² (AWG 22) | 0,75 mm² (AWG 20) | 1 mm² (AWG 18) | |
| Crimpstation | 4 | 5 | 6 | |
| Querschnitt | 1,5 mm² (AWG 16) | 2,5 mm² (AWG 14) | 4 mm² (AWG 12) | |

Stand: 07.10.2014

Die- sets for MP 1 and MP 2
for cord- end sleeves

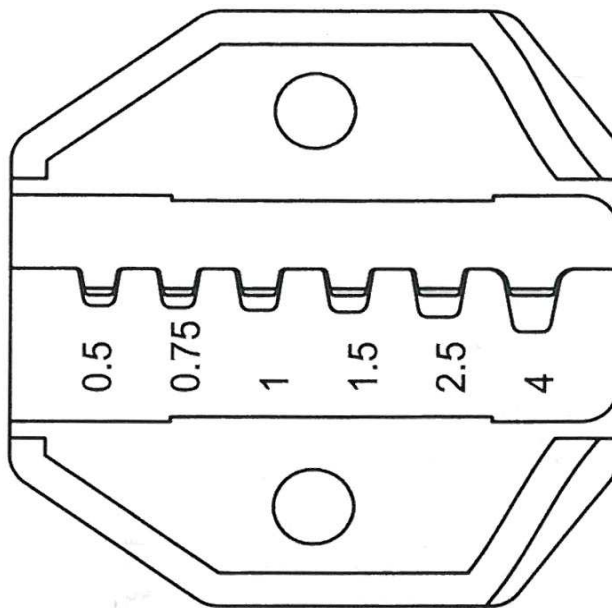
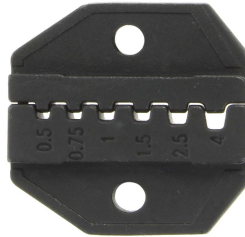

| | | | | |
|-------------------------|---------------------------------|----------------------------------|-------------------------------|----------|
| part no. | crimping type | | | |
| W 9060809 | trapezoid | | | 1 |
| crimping station | 1 | 2 | 3 | |
| cross- section | 0,5 mm ² (AWG 22) | 0,75 mm ² (AWG 20) | 1 mm ² (AWG 18) | |
| crimping station | 4 | 5 | 6 | |
| cross- section | 1,5 mm ² (AWG 16) | 2,5 mm ² (AWG 14) | 4 mm ² (AWG 12) | |

date: 07.10.2014